



KONY ELECTRONIC





COLOURS



**MACINADOSATORE KONY
ELETTRONICO CON MACINE CONICHE**

REGOLAZIONE DI MACINATURA
MICROMETRICA CONTINUA

- Macinatura istantanea
- Regolazione elettronica della dose
- Ventilazione elettronica

CARATTERISTICHE TECNICHE:

Potenza	450 Watt
Macine coniche (rif. 191C)	Ø 63 mm
Giri macine	420 (50 Hz) g/min 500 (60 Hz) g/min
Capacità contenitore caffè in grani	1,3 Kg
Peso netto	20 Kg



**GRINDER-DOSER KONY ELECTRONIC
WITH CONICAL GRINDING BLADES**

STEPLESS MICROMETRICAL
GRINDING ADJUSTMENT

- Grinding on demand
- Electronic dose adjustment
- Ventilation with electronic control

CARATTERISTICHE TECNICHE:

Power	450 Watt
Conical grinding blades (ref. 191C)	Ø 63 mm (2½ inches)
Grinding blade speed	420 (50 Hz) r.p.m. 500 (60 Hz) r.p.m.
Coffee-bean container capacity	1,3 Kg (2,9 lbs)
Net weight	20 Kg (44 lbs)



**MOULIN DOSEUR KONY
ÉLECTRONIQUE AVEC MEULES CONIQUES**

RÉGULATION DE MOUTURE
MICROMÉTRIQUE CONTINUE

- Mouture instantanée
- Réglage électronique de la dose
- Ventilation électronique

CARACTÉRISTIQUES TECHNIQUES:

Puissance	450 Watt
Meules coniques (réf. 191C)	Ø 63 mm
Tours meules	420 (50 Hz) tr/min 500 (60 Hz) tr/min
Contenance de la trémie	1,3 Kg
Poids net	20 Kg



**DOSIERMÜHLE KONY ELEKTRONISCH
MIT KONISCHE MAHLSCHEIBEN**

STUFENLOSE MIKROMETRISCHE
MAHLREGELUNG

- Augenblickliches Mahlen
- Elektronische Einstellung der Dosis
- Elektronisch-kontrollierte Luftung

TECHNISCHE DATEN:

Leistung	450 Watt
Mahlscheiben konischen (Kennziffer 191C)	Ø 63 mm
Mahlscheibenumdrehungen	420 (50 Hz) r.p.m. 500 (60 Hz) r.p.m.
Kapazität des Bohnenbehälters	1,3 Kg
Nettogewicht	20 Kg



**MOLINO DOSIFICADOR KONY
ELECTRÓNICO CON FRESAS CONICAS**

REGULACIÓN MOLIENDA
MICROMÉTRICA CONTINUA

- Molidura instantánea
- Regulación electrónica de la dosis
- Ventilación electrónica

DATOS TÉCNICOS:

Potencia	450 Watt
Fresas conicas (ref. 191C)	Ø 63 mm
Revoluciones fresas	420 (50 Hz) r.p.m. 500 (60 Hz) r.p.m.
Capacidad de la tolva	1,3 Kg
Peso neto	20 Kg



**MOINHO DOSEADOR KONY
ELECTRÓNICO COM MÓIS CONICAS**

REGULAÇÃO DA MOAGEM
MICROMÉTRICA CONTÍNUA

- Moagem instantânea
- Regulação electrónica de dose
- Ventilação electrónica

DADOS TÉCNICOS:

Potencia	450 Watt
Móis conicas (ref. 191C)	Ø 63 mm
Rotações dos mós	420 (50 Hz) r.p.m. 500 (60 Hz) r.p.m.
Capacidade tremonha	1,3 Kg
Peso líquido	20 Kg

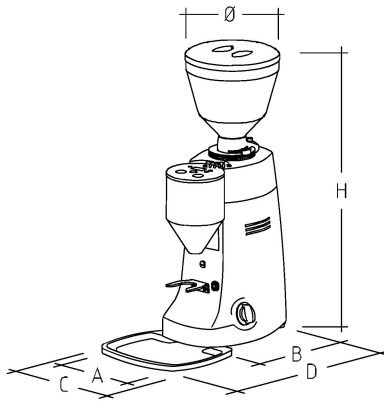

	mm	inches
A	206	8 ¼
B	263	10 ½
C	240	9 ½
D	420	16 ½
H	650	25 ½
Ø	212	8 ¼

CERTIFICATIONS



• Il costruttore si riserva la facoltà di apportare quelle modifiche tecniche che si rendessero necessarie senza preavviso. • The manufacturer reserves the right to change specifications without notice. • Le constructeur se réserve le droit d'effectuer des modifications sans aucun préavis. • Der Hersteller vorbehaltet sich den technischen Daten warnunglos zu ändern. • El constructor se reserva el derecho de efectuar sin previo aviso las modificaciones que considere oportunas en interés de mejoras técnicas en sus fabricados. • O constructor reserva-se o direito de modificar sem aviso previo as máquinas tratadas neste manual.