

zumex®

Speed Pro

The fastest and most robust

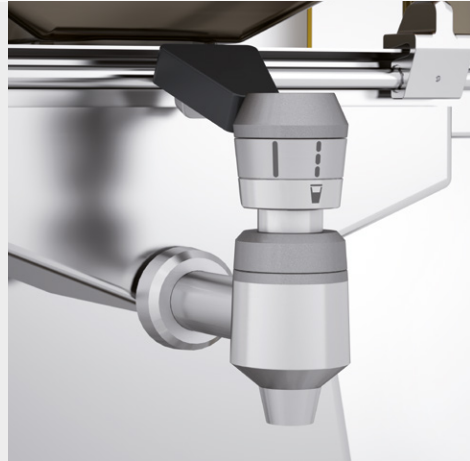
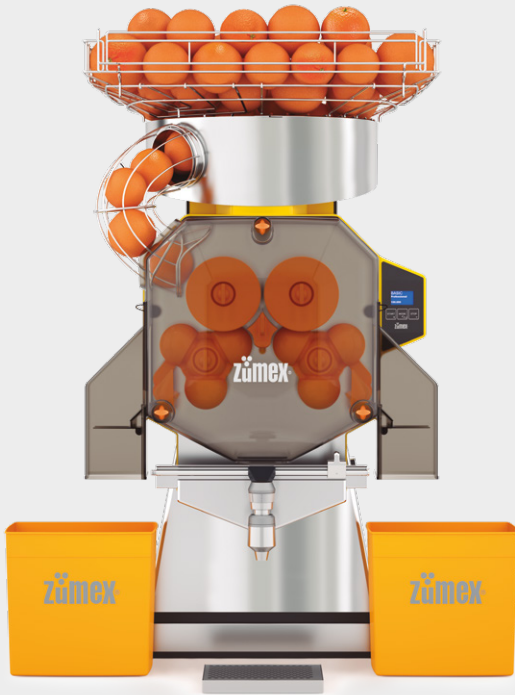

The best-prepared series to provide **an efficient, safe and impeccable service**, designed to satisfy large juice demands.

The **tabletop models** adapt perfectly to tables or counters of self-service areas in hotels or cafeterias, offering an easy and fast juice service.

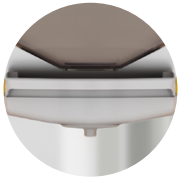

Speed Pro Basic

Speed Pro Basic

- Model indicated for restaurants with a high juice demand due to its **capacity and easy cleaning**. Ideal for your convenience.
- It allows you to program the desired number of fruits to be squeezed.
- It includes an orange counter.

Dimensions	59.3 x 57.4 x 98.9 cm 23.3" x 22.6" x 38.9"	Net weight	64.7 Kg 142.4 lb
-------------------	--	-------------------	---------------------

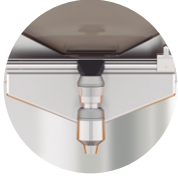

Speed Pro Self Service

Speed Pro Self Service

- It is characterised by its **autonomy and adaptability** to restaurants, self-services and hotel buffets. It revolutionizes the self-service world.
- With its **self-service tap**, the squeezing system is activated automatically.

Dimensions	59.3 x 65.8 x 105 cm 23.3" x 25.9" x 41.3"	Net weight	72 Kg 159.4 lb
-------------------	---	-------------------	-------------------

Type of consumption



With Original System and ASP anti-bacterial system.

Technical Characteristics

Fruits per minute	40	Consumption	1.2 A 2.7 A
Feeder capacity	20 Kg 44 lb	Voltage	120 V 60 Hz
Fruit size	65 - 81 mm	Power	300 W 0.40 HP
Litres per minute	2.5 - 4.5 l / min	Security	Triple safety detector and motor seizure detection

Accessories



Kit S Squeezing
Kit (45 - 67 mm)



Kit L Squeezing
Kit (75 - 95 mm)



Dynamic Cutting
System DCS



Countertop
Kit



Zumex Pack