

IL ROTANTE Tondo



DIAMETRO INTERNO
INTERNAL DIAMETER

Ø150cm

Gas / Backup elettrico - Gas / electrical backup COD. FR15SF

INGOMBRO ESTERNO 195x195 CM
EXTERNAL DIMENSION 195x195CM



La cottura più facile ed omogenea

Grazie alla rotazione del piano cottura, i forni rotanti hanno rivoluzionato il mestiere del pizzaiolo e non solo.

Grazie a questa nuova tecnologia la cottura della pizza viene gestita interamente dal forno, che con il suo movimento rotatorio distribuisce il calore uniformemente in ogni punto, eliminando di fatto il lato radiante.

Questo permette di non dover seguire la cottura girando le pizze e quindi dedicare il lavoro principalmente alle fasi di stesura e condimento, garantendo maggiori volumi di infornate e minori tempi di attesa.

Most efficient and easy baking

Maximum space rationality: four perpendicular walls allow the structure to fit perfectly in the layout of your restaurant. External design is customizable thanks to a wide choice of coverings. Solutions with high visual impact make this model an ideal piece of furniture for your restaurant. Round cooking chamber guarantees the most favourable heat diffusion and circulation.



STRUTTURA STRUCTURE

Cupola e piano di cottura costruiti a mano in mattoni refrattari



Vault and cooking deck hand-made refractory fire-bricks

TIPI DI ALIMENTAZIONE POWER SUPPLY

Gas / backup elettrica

Gas / electrical backup



CAPACITÀ PRODUTTIVA TEORICA THEORETICAL PRODUCTION CAPACITY

Grandi produzioni - Big production

Numero pizze* per infornata
*Number of pizzas**

13

*pizze da Ø 30cm
*30cm Ø pizzas



Produzione media oraria
Average hourly production

312/h

infornata da 2.30min a pieno carico
2.30min batches at full load



ASSEMBLAGGIO BUILDING

- Montato sul posto
- Pre assemblato in fabbrica

- *On site building*
- *Shipped already built*



PIANO DI COTTURA COOKING DECK

Piano di cottura rotante

Rotating cooking deck



BOCCA FORNO OPENING

Apertura bocca standard
Standard door opening



larghezza *width* 52 cm
altezza *height* 26 cm

PANNELLO DI CONTROLLO CONTROL PANEL

Controllo touch screen con esclusivo telecomando per controllo a distanza



Touch screen and remote for an easy and fast control

ALLACCIO CANNA FUMARIA CHIMNEY CONNECTION

Femmina diametro interno
Female internal diameter

200mm



PESO WEIGHT

2600



CARATTERISTICHE MAIN FEATURES

Controllo della fiamma elettronico: termostabile o manuale
Electronic flame controls: thermostatic or manual



I prodotti sono realizzati artigianalmente
Le misure possono subire variazioni
Products are handmade - Measures
may change



ceky
FORNI DAL 1935

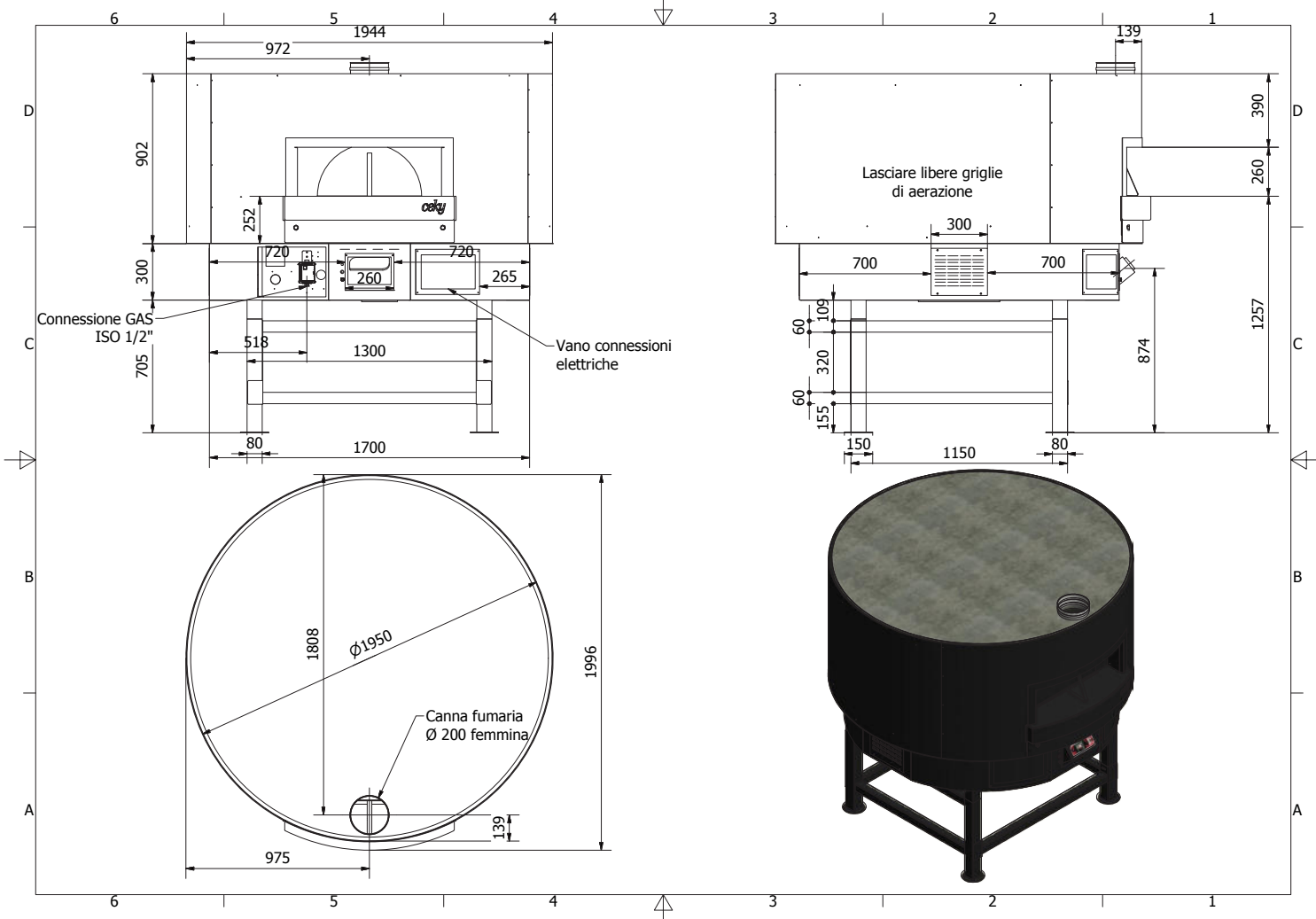

DATI TECNICI TECHNICAL DETAILS

Potenza termica nominale (BTU) <i>Nominal thermal power</i>	97500
Allacciamento Gas ISO 7-1 <i>Gas inlet connection ISO 7-1</i>	3/4"
Categoria <i>Category</i>	II 2H3+
Regolazione di fabbrica <i>Factory setup</i>	Gas metano <i>Natural gas</i>
Tipo di costruzione <i>Construction type</i>	A1/B11 _{BS}
Pressione di allacciamento gas (IWC) <i>Gas pressure (IWC)</i>	G 30/G 31: 12 / 14.8 G20: 8
Consumo di gas complessivo calcolato con il potere calorifico inferiore Hi a 15" e 1013 mbar <i>Gas consumption</i>	G30 (Kg/h) 2.25 - G20 (m3/h) 3.03
Alimentazione nominale <i>Nominal power supply</i>	120/208V 4 conductor 3P+N+G 60Hz
Potenza assorbita <i>Absorbed power</i>	6500W

IMBALLO PACKING

Bancale HT ISPM15 scatolato in cartone con coperchio ISPM15
HT ISPM15 pallet with cardboard box and ISPM15 cover

2000 x 2000mm
H 1600mm



DECORAZIONI DISPONIBILI AVAILABLE DECORATIONS

Mattoni - mattonelle - palladiane - mosaici
Bricks - tiles - marble - mosaic



ULTERIORI PERSONALIZZAZIONI FURTHER CUSTOMIZATION

Su richiesta
Upon request

