

SCREW ROUNDER SFERA



Date _____
 Project _____
 Location _____

| MODEL | ITEM CODE |
|-----------------------|-----------|
| SCREW ROUNDER "SFERA" | S02-SFERA |

General technical characteristics:

- Interchangeable aluminium endless;
- Stainless steel Output Tray;
- NSF certified plastic cylinder;
- CE certification.

The screw rounder model "Sfera" is ideal for rounding pieces of all kind of dough from 30 g to 1000 g both with hard and soft or very humid dough. Very easy to use and practical to dismount for cleaning, it has a very reduced consumption thanks to the single phase tension. The machine is able to mould more than 1800 pieces/hour and can be used both in pizzerias and bakeries. The rounding system makes use of both the gravity and the centrifugal force limiting at the minimum the pressure on the dough. This allows not to alter its temperature and elasticity avoiding the stress. Built in stainless steel, with a powerful motor and a simple mechanics, it is a very reliable machine. The rotating cylinder in plastic material is certified for alimentary use.



Technical Data

Dimensions

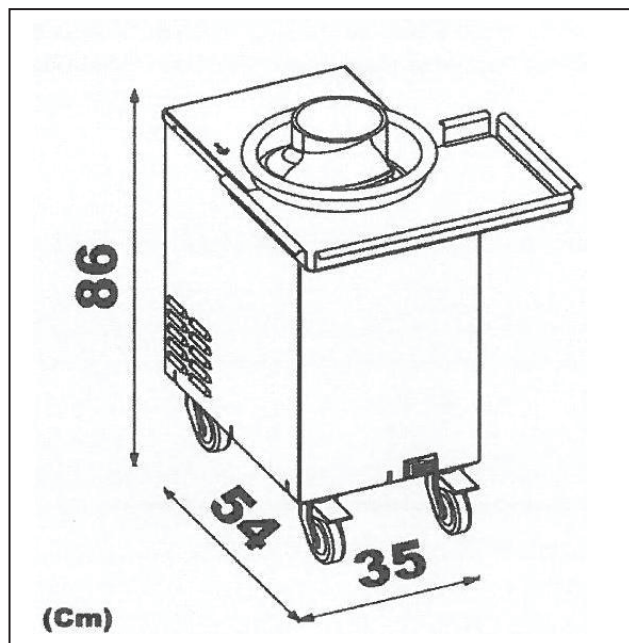

Voltage: 115V/60Hz
(*Optional:* special voltages)

Power: .0,37 Kw

Phase: Single phase

Choice models of cochle:

"A" for pizzeria dough

"B TEFLON" Recommended for high hydration dough or pastry

Production rate: 20-1000 gr

Max production for hour: 1800 pz/h

Shipping information

| Model | Net weight | Gross weight | |
|-------|---------------|----------------|---------------|
| | | Pallet | Crate |
| SFERA | 60kg (132 lb) | kg 75 (165 lb) | 85kg (187 lb) |

Information on the packaging

| MODEL | Box on pallet | | Cage/Crate | |
|-------|----------------------------|-----------------------------|----------------------------|-----------------------------|
| | Dimensions [mm] | Volume [m ³] | Dimensions [mm] | Volume [m ³] |
| SFERA | 490x630x1020 (20"x25"x40") | 0.32 (11 ft ³) | 490x630x1020 (20"x25"x40") | 0,32 (11 ft ³) |

