

# AMALFI - "C1"

MODULAR ELECTRIC OVEN FOR PIZZERIA  
COMPOSITION WITH 1 BAKING CHAMBER

Date \_\_\_\_\_

Project \_\_\_\_\_

Location \_\_\_\_\_

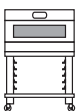
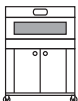

		MODEL	ITEM CODE
	<ul style="list-style-type: none"> <li>— AMALFI K COMP 1/S</li> <li>— AMALFI C/18 Z</li> <li>— AMALFI B With stand</li> <li>— AMALFI S/95 Avec support</li> </ul>	<input type="checkbox"/> cm 132 x 140 x 160 <input checked="" type="checkbox"/> cm 95 x 103 x 18 kW max 9,6	M01-AMALFI-C-1/S
	— castors - roues		
	<ul style="list-style-type: none"> <li>— AMALFI K COMP 1/SP</li> <li>— AMALFI C/18 Z</li> <li>— AMALFI B</li> <li>— AMALFI SP/95</li> </ul>	<input type="checkbox"/> cm 132 x 140 x 160 <input checked="" type="checkbox"/> cm 95 x 103 x 18 kW max 9,6	M01-AMALFI-C-1/SP
	With stand with trayholder slides Avec support avec glissieres porte plateau — castors - roues		
	<ul style="list-style-type: none"> <li>— AMALFI K COMP 1/L</li> <li>— AMALFI C/18 Z With proofer</li> <li>— AMALFI B Avec étuve</li> <li>— AMALFI L/80</li> </ul>	<input type="checkbox"/> cm 132 x 140 x 145 <input checked="" type="checkbox"/> cm 95 x 103 x 18 kW max 11,1	M01-AMALFI-C-1/L
	— castors - roues		

## OPTIONS AND ACCESSORIES (WITH SURCHARGE)

- Proofing cabinet with wheels, Height 800 mm (31 1/2")
- Stand with wheels, height 600 mm (23 5/8")
- Stand with wheels, height 800 mm (31 1/2")
- Stand with wheels, height 950 mm (37 3/8")
- Additional tray holder guides for compartment and stand
- Spacer element height 300 mm (11 13/16")
- Suction hood

### (WITHOUT SURCHARGE)

- Front vapour collection hood in stainless steel sheet

## EXTERNAL CONSTRUCTION

- All-round stainless steel body
- Stainless steel vapour collection hood with pre-painted metal sheet panelling
- Side panels in pre-painted sheet metal
- Steam duct in stainless steel plate
- Stainless steel door with spring balance bottom hinge
- Tempered insulated glass windows
- High quality thermoplastic door and chimney handles
- Electronic control panel

## INTERNAL CONSTRUCTION

- All-around refractory brick baking chamber with internal spiral resistors
- Stainless steel chamber side guards
- High-density rock wool insulation
- Internal protected lighting with incandescent lamp
- Front blade heat saver

## OPERATION

- Electronic control panel with soft-touch buttons
- Independently regulate ceiling and floor heating elements
- Maximum temperature reached 450°C (840°F)
- Continuous temperature monitoring with thermocouple
- Vapour ducting using manual butterfly valve

## STANDARD EQUIPMENT

- Lighting with incandescent lamp
- Timer
- Economizer
- Independent maximum temperature safety device



# Technical Data

## AMALFI "C" 1 CHAMBER (assembled with stand height 950 mm)

TOP VIEW

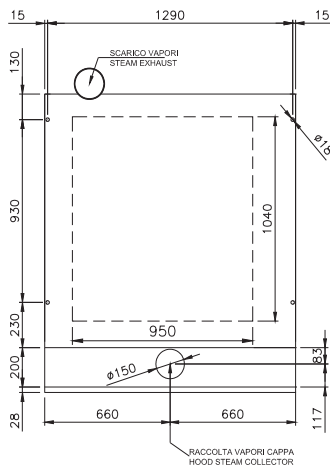

REAR VIEW

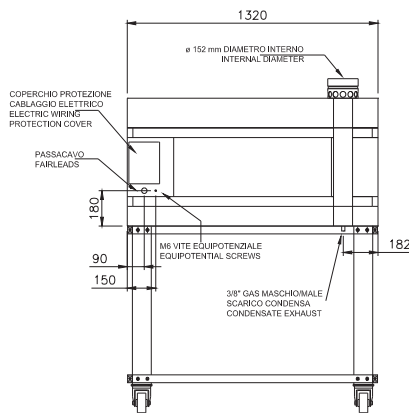

VIEW FROM RIGHT

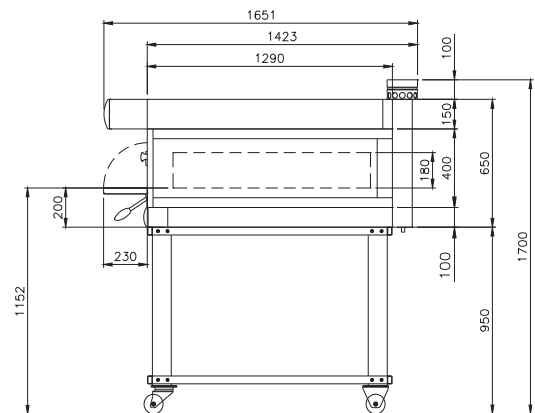

**Note:** The dimensions indicated in the views are in millimetres.

### SPECIFICATIONS

The **Amalfi Type C1** is composed by one (1) independently powered cooking chamber, and a stand or an optional proofing cabinet. The baking chamber entirely built in refractory brick and the heating elements inside the stone, guarantee perfectly even heat distribution throughout the surface, which makes the Amalfi model an ideal deck oven for pizzerias. The oven reaches a maximum temperature of 450°C (840°F). The temperature controls are electronic with independent controls for the ceiling and floor heating elements. The chambers doors are bottom hinged with a wide tempered glass window for constant visual monitoring during the baking process. The stand is composed by a painted metal structure, whereas the proofing cabinet has a stainless steel structure and is fitted with a 65°C (150°F) manual thermostat, internal lighting and slide guides for baking sheets. The proofing cabinet can be used for prepping or as a temporary heated storage, thanks to the doors magnetic fasteners that ensure a secure closure.

All the data provided below refer to the configuration with 1 baking chamber

#### DIMENSIONS

External height	750 mm (29 1/2")
External depth	1651 mm (65")
External width	1320 mm (52")
Weight	293 kg (646)
Baking surface	1 m <sup>2</sup> (10.76 ft <sup>2</sup> )

#### SHIPPING INFORMATION

Packed in wooden crate	
Height	900 mm (35 7/16")
Depth	1851 mm (72 7/8")
Width	1520 mm (59 7/8")
Weight	303 kg (668)

#### POWER SUPPLY

A.C. V240 3ph 60Hz	
Max power	10.5 kW (25.1 amps)
*Medium consumption/hour	5.2 kWh (12.5 amps)

#### TOTAL BAKING CAPACITY

Pizza diameter 300 mm (12")	9	When combined with leavening compartment or stand:
Pizza diameter 450 mm (18")	3	Max height 1850 mm (72 13/16")
Tray (450x450) mm	4	Max weight 413 kg (910 lb)
Tray 26"X18"	2	

#### Proofer feeding

A.C.V240 1ph 60 Hz	
Max power	1.5 kW (7.5 amps)
*Medium consumption/h	0.8 kWh(3.7 A)

\* This value is subject to variation according to the way in which the equipment is used.

Euro-Milan/ MORETTI FORNI S.P.A. reserves the right to modify the characteristics of the products illustrated in this publication without prior notice. We accept no liability for misprints and other errors. There may be colour deviations due to the printing process.

