

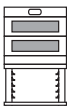

AMALFI - "B2"

MODULAR ELECTRIC OVEN FOR PIZZERIA
COMPOSITION WITH 2 BAKING CHAMBER

Date _____
Project _____
Location _____



	MODEL	ITEM CODE
 <ul style="list-style-type: none"> ← AMALFI K COMP 2/S ← AMALFI C/18 Z ← AMALFI C/18 Z With stand ← AMALFI B Avec support ← AMALFI S/80 ← castors - roues 	<input type="checkbox"/> cm 132 x 110 x 185 <input checked="" type="checkbox"/> cm 95 x 73 x 18 kW max 14,2	M01-AMALFI-B-2/S
 <ul style="list-style-type: none"> ← AMALFI K COMP 2/SP ← AMALFI C/18 Z ← AMALFI C/18 Z ← AMALFI B ← AMALFI SP/80 ← With stand with trayholder slides ← Avec support avec glissieres porte plateaux ← castors - roues 	<input type="checkbox"/> cm 132 x 110 x 185 <input checked="" type="checkbox"/> cm 95 x 73 x 18 kW max 14,2	M01-AMALFI-B-2/SP
 <ul style="list-style-type: none"> ← AMALFI K COMP 2/L ← AMALFI C/18 Z With prover ← AMALFI C/18 Z Avec étuve ← AMALFI B ← AMALFI L/80 ← castors - roues 	<input type="checkbox"/> cm 132 x 110 x 185 <input checked="" type="checkbox"/> cm 95 x 73 x 18 kW max 15,7	M01-AMALFI-B-2/L

OPTIONS AND ACCESSORIES (WITH SURCHARGE)

- Proofing cabinet with wheels, height 800 mm (31 1/2")
- Stand with wheels, height 600 mm (23 5/8")
- Stand with wheels, height 800 mm (31 1/2")
- Stand with wheels, height 950 mm (37 3/8")
- Additional tray holder guides for compartment and stand
- Spacer element height 300 mm (11 13/16")
- Suction hood

(WITHOUT SURCHARGE)

- Front vapour collection hood in stainless steel sheet

EXTERNAL CONSTRUCTION

- All-around stainless steel body
- Stainless steel vapours collection hood with aluminised steel top cover
- Front vapour collection hood in enamelled steel sheet
- Side panels in pre-painted sheet metal
- Steam duct in stainless steel plate
- Stainless steel door with bottom hinge and spring balance
- Tempered insulated glass windows
- High quality thermoplastic door and chimney handles
- Electronic control panel

INTERNAL CONSTRUCTION

- All-around refractory brick baking chamber with internal spiral resistors
- Stainless steel chamber side guards
- High-density rock wool insulation
- Internal protected lighting with incandescent lamp
- Front blade heat saver

OPERATION

- Electronic control panel with soft-touch buttons
- Independently regulate ceiling and floor heating elements
- Maximum temperature reached 450°C (840°F)
- Continuous temperature monitoring with thermocouple
- Vapour ducting using manual butterfly valve

STANDARD EQUIPMENT

- Lighting with incandescent lamp
- Timer
- Economizer
- Independent maximum temperature safety device



Technical Data

AMALFI "B" 2 CHAMBERS (assembled with stand height 800 mm)

TOP VIEW

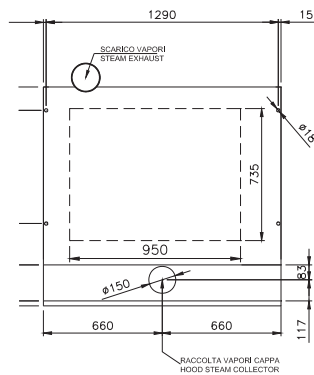

REAR VIEW

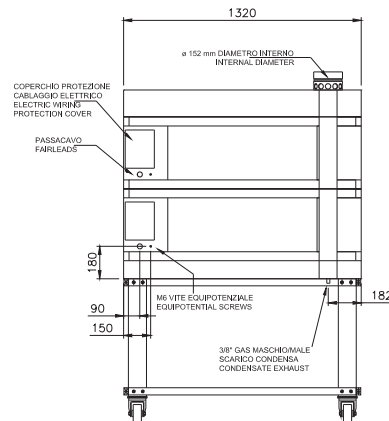

VIEW FROM RIGHT

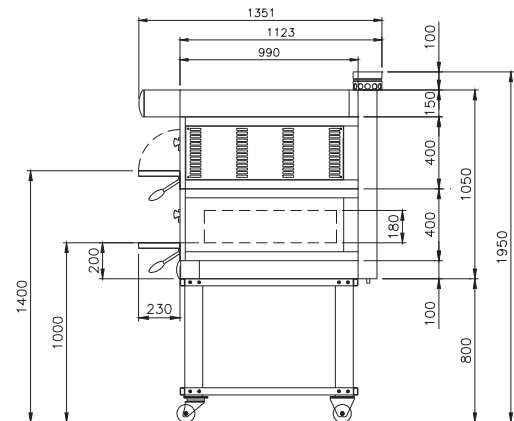

Note: The dimensions indicated in the views are in millimetres.

SPECIFICATIONS

The **Amalfi Type B2** is composed by two (2) independently powered cooking chambers, and a stand or an optional proofing cabinet. The baking chamber entirely built in refractory brick and the heating elements inside the stone, guarantee perfectly even heat distribution throughout the surface, which makes the Amalfi model an ideal deck oven for pizzerias. The oven reaches a maximum temperature of 450°C (840°F). The temperature controls are electronic with independent controls for the ceiling and floor heating elements. The chambers doors are bottom hinged with a wide tempered glass window for constant visual monitoring during the baking process. The stand is composed by a painted metal structure, whereas the proofing cabinet has a stainless steel structure and is fitted with a 65°C (150°F) manual thermostat, internal lighting and slide guides for baking sheets. The proofing cabinet can be used for prepping or as a temporary heated storage, thanks to the doors magnetic fasteners that ensure a secure closure.

All the data provided below refer to the configuration with 2 baking chambers

DIMENSIONS

External height	1150 mm (45 1/4")
External depth	1351 mm (53 3/16")
External width	1320 mm (52")
Weight	410 kg (904 lb)
Total baking surface	1.4 m ² (15 ft ²)

SHIPPING INFORMATION

Packed in wooden crate	
Height	1250 mm (49 2/8")
Depth	1551 mm (61 1/16")
Width	1520 mm (59 7/8")
Weight	420 kg (926 lb)

POWER SUPPLY

A.C. V240 3ph 60Hz	
MAX POWER each deck	7.7 kW (18.5 amps)
*Medium consumption/h	3.8 kWh (9.2 amps)

TOTAL BAKING CAPACITY

Pizza diameter 300mm (12")	12
Pizza diameter 450mm (18")	4
Tray (600x400) mm	4
Tray 26"x18"	4

When combined with proofing cabinet or stand:

Max height	2200 mm (86 5/8")
Max weight	515 kg (1168 lb)

Each deck requires separate electrical connection

Proofer feeding	
A.C. V240 1ph 60 Hz	
Max power	1.5 kW (7.5 amps)
*Medium consumption/h	0.8 kWh (3.7 amps)

* This value is subject to variation according to the way in which the equipment is used.

Euro-Milan/ MORETTI FORNI S.P.A. reserves the right to modify the characteristics of the products illustrated in this publication without prior notice.
We accept no liability for misprints and other errors. There may be colour deviations due to the printing process.

