

# ITWIN 60

## TWIN ARM KNEADING MACHINE



Date \_\_\_\_\_  
Project \_\_\_\_\_  
Location \_\_\_\_\_



- Steel structure painted using non-toxic paints with food-grade certification
- Made of outstandingly thick stainless steel with a reinforcement at the base. Available in three versions 40, 50 and 60 kg
- Made of spheroidal cast iron immersed in an oil bath to guarantee silence and durability
- All the machines comply with CE standards and regulations and are produced in Italy. Components/adaptation to meet the UL/CSA standard (non-certified product)
- Self-braking two-speed motor. Available in 3-phase 2 speed version and a single-phase version with variable speed (INVERTER)
- Standard supply of all the machines include 400/230 Volt 60 Hz 3or1 phase connections. On request, they can be supplied with different voltages
- Drive transmission with pulleys and trapezoidal belts to guarantee maximum silence and reliability. The bowl is connected to a gear motor
- Anti-shock plexiglass shield. It complies with all health and hygiene regulations (Food processing machinery - Dough mixers - Safety and hygiene requirements EN 453:2000+A1:2009)
- It is equipped with wheels for handling and two stabilising feet, in order to maintain the required hygienic level in your laboratory. Adjustable front support feet



## Technical Data

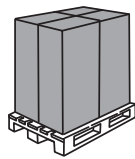
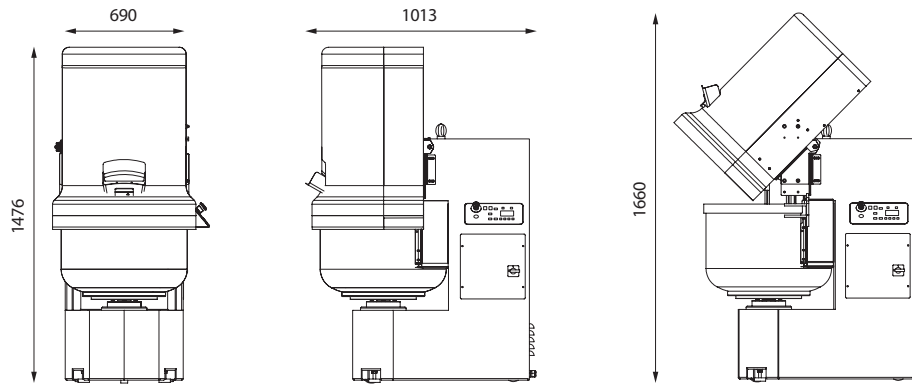

80x115x165h  
340 kg

bancale e cartone di serie  
standard carton pallet



86x121x167h  
385 kg

gabbia in legno su richiesta  
wooden crate on request

### iTWIN60/MAN - iTWIN60/PRO - iTWIN60/INV - iTWIN60/INVm

Dough capacity (min/max)*		kg	5/61
Flour capacity (min/max)*		kg	3/38
Water capacity (min/max)*		lt	2/23
Bowl volume		lt	92
Water / flour min		%	50
Twin arms turns	1 <sup>st</sup> /2 <sup>nd</sup> speed	MAN - PRO	rpm 40/60
	inverter	INV - INVm	rpm from 30 to 70
Bowl turns	1 <sup>st</sup> /2 <sup>nd</sup> speed	MAN - PRO	rpm 8/12
	inverter	INV - INVm	rpm from 6 to 14
Bowl dimension (D x H)		mm	550x390
Motor power	1 <sup>st</sup> /2 <sup>nd</sup> speed	MAN - PRO	Kw 1.1/1.5
	inverter	INV - INVm	Kw 1.5
Volt		MAN - PRO - INV	V 400/3/50-60
		INVm	V 230/1/50-60
Electric motor brake			included
Net weight		kg	314

Dough capacity calculated with 60%  
of hydration. The maximum capacity may vary depending on the ingredients.

Euro-Milan reserves the right to modify the characteristics of the products illustrated in this publication without prior notice.  
We accept no liability for misprints and other errors. There may be colour deviations due to the printing process.

